

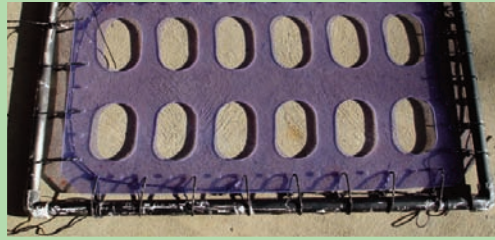

# Response of Yellowfin Tuna to Different Sorting Grids for Reducing Juvenile Bycatch

Peter Nelson, Sea Grant Extension, Eureka, California



## Background

For reasons that elude marine biologists, a handful of fish species in all the world's oceans tend to congregate beneath floating objects—be they mats of algae, logs, bobbing coconuts or plastic debris.

Fishermen utilize this tendency by deploying special buoys known as fish aggregation devices, or FADs. By attracting fish to set areas, FADs greatly increase the efficiency of fishing operations. FADs are especially popular with the international tuna purse seine fleet in the tropical eastern Pacific Ocean, one of the world's major centers of tuna fishing.

A downside of FAD-assisted fishing is that it leads to the harvest of many juvenile tunas that have not yet reproduced. This phenomenon has contributed to the depletion of bigeye tuna and could have implications for the spawning biomass of other tunas as well. FAD-assisted fishing has also increased incidental takes of sharks and endangered sea turtles.

## Project

In an effort to develop commercially viable solutions for reducing bycatch in 2003, Peter Nelson, then a postdoctoral researcher at the Center for Marine Biodiversity and Conservation at Scripps Institution of Oceanography, received funding from the Inter-American Tropical Tuna Commission (IATTC) to compare behaviors of juvenile yellowfin tuna to six experimental sorting grids—devices in fishing nets that would allow small tunas to escape.

The idea was to identify specific design elements that might increase the number of juveniles able to escape before the purse seine net is hoisted onto deck. Ideally, some kind of optimal sorting grid would be built into commercial purse seine nets to reduce juvenile tuna bycatch.

**How Big the “Holes”?** – The first step of the project was to determine how big to make the gaps in a sorting grid. To do this, staff at the Inter-American Tropical Tuna Commission (IATTC) laboratory in Panama caught and measured the length, width and depth of 47 yellowfin tuna. Their measurements suggested that a 100 mm by 150 mm rectangular or oval hole (about the size of a 4” x 6” photo) would be sufficient to allow passage of a 4-kilogram yellowfin tuna.

**Experimental Sorting Grids** – With these dimensions in hand, six grids were tested. Four were constructed of a series of five polyvinyl chloride (PVC) pipes spaced slightly more than 150 mm apart. They varied in orientation of the pipes, vertical or horizontal, and in color, black or white. A fifth grid was made by cutting a series of oval holes in a thick PVC sheet, and the sixth by sewing a series of rigid rings into purse seine netting.

**Tank Experiments with Yellowfin** – These designs were tested in a series of laboratory tank experiments, conducted at the IATTC laboratory in Panama, using yellowfin tunas caught off Panama by IATTC staff. In each trial, six fish were placed between Net A and Net B, with two different grid designs in the F1 and F2 portions of Net B. See Figure 1 on back page.

At the beginning of each trial, the pie-slice (or angle) between the nets was slowly constricted, progressively concentrating fish into a smaller volume of water. This action, analogous to “drying up” a purse seine net, forced fish to choose between exiting through the grid configurations in the F1 and F2 positions. The scientists recorded the relative escapement rates through each grid design.

The observed escapement rates showed that fish moved through a vertical PVC grid more readily than a horizontal one, and through a white grid more readily than a black one. Fish were able to exit through a vertically oriented white grid more than twice as fast as a horizontal, black one. The color differential may be due to the

## California Sea Grant Extension Program

Russell A. Moll, Director • Paul Olin, Extension Director • Marsha Gear, Communications Director  
University of California, San Diego, 9500 Gilman Drive, Dept. 0232, La Jolla, CA 92093-0232  
Communications Phone: (858) 534-4446 • Fax: (858) 453-2948 • Web: <http://www.csgc.ucsd.edu>

greater contrast between the white grid and the dark background of the tank in which the experiments were conducted, the scientists reported. They have no clear theory for why the vertically oriented grid facilitated escapement.

The PVC window panel was tested against only one grid design—the rings—but in these tests, the window was strikingly effective at helping fish escape. “Fish apparently perceive the large, clear panel as a large, clear opening in the net,” Nelson said. “We’re eager to conduct further experiments.”

**Bubble Net** – Some whale species, particularly humpbacks, herd prey species by blowing bubbles beneath them. As these bubbles ascend, prey find themselves surrounded by a curtain of bubbles or bubble net. To test the tunas’ response to bubble nets, scientists streamed air through a porous hose placed across the bottom of the tank. They then watched the tunas’ response to the curtain of air bubbles. The fish were loath to swim through the bubble net, Nelson said. This aversion occurred even when a diver entered the tank and tried to herd fish through it.

Nelson believes that artificial bubble nets like the one they created for the experiments may be a way to herd fish in a purse seine toward a sorting grid. Or, he said, because fish do tend to segregate by size, a bubble curtain could function as an easily operable “gate,” permitting the escape of small fish or unwanted species.

## Conclusions

“We have demonstrated that at least two gear designs are worthy of further testing,” Nelson said. “With the appropriate combination of incentives and training, a relatively small device could reduce bycatch. It won’t reduce bycatch to zero, but even a 20-percent reduction would be significant.”

## Sponsors

Inter-American Tropical Tuna Commission, U.S. Tuna Foundation, Center for Marine Biodiversity and Conservation, Scripps Institution of Oceanography

## Publications

Poster presented at the International Council for the Exploration of the Sea (ICES) Fishing Technology Symposium, Boston, 2006

“Reducing Unintended Catch of Bigeye Tuna Near FADs,” California Sea Grant Fisheries Newsletter, Fall, 2006

Paper in review with ICES Journal of Marine Science

## For More Information

Peter Nelson, Marine Advisor, Del Norte & Humboldt Counties Sea Grant Extension Program, Eureka, California  
Tel: 707.443.8369 • Email: [panelson@ucdavis.edu](mailto:panelson@ucdavis.edu)



Peter Nelson

## Photo Credits

(Front left) NOAA, (Front center and right) P. Nelson  
(Back diagram) P. Nelson (Back portrait) California Sea Grant Extension

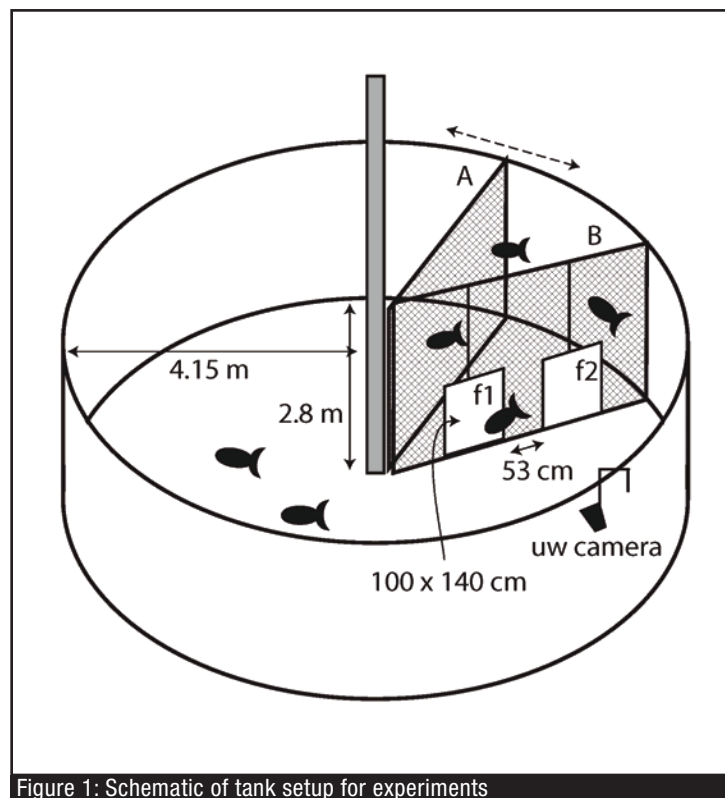

Figure 1: Schematic of tank setup for experiments



This publication is sponsored by a grant from the National Sea Grant College Program, National Oceanic and Atmospheric Administration, U.S. Department of Commerce, under grant number NA04OAR4170038, Project number C/P-1. The views expressed herein are those of the authors and do not necessarily reflect the views of NOAA or any of its sub-agencies. The U.S. government is authorized to reproduce and distribute for governmental purposes. *This document is available in PDF on the California Sea Grant website: [www.csgc.ucsd.edu](http://www.csgc.ucsd.edu).*